



MODEL 901[©]
(1980-MSRP \$289.00)

OWNER'S MANUAL AND INSTALLATION GUIDE

INTRODUCTION

Your new **Linear Power™ 901[©]** amplifier employs a sophisticated design combining reliability, high power, low distortion, and freedom from external noise. When properly installed, it will give long and faithful service. When combined with other high quality components, it will be the heart of a superb system. Thank you for purchasing a **Linear Power™** Product.

INSTRUCTIONS

Read the following instructions completely through. If they appear too complicated, we recommend that you have an authorized **LINEAR POWER™ Dealer** do the work.

MOUNTING

- 1. Amplifier Cooling:** The amplifier will operate best if it is kept as cool as possible. Mount in a position that allows air to flow freely through the fins. Be sure there is ample space above the amplifier to avoid trapping heated air rising from the amplifier. The amplifier should not be mounted upside down.
- 2. Accessibility:** Mount your amplifier in a position that allows ample room for installation, removal and attachment of leads, and gain adjustments.
- 3. Insulation:** Be sure that the metal case of the amp does not touch the metal of the car. Do not remove or damage the rubber grommets that provide electrical insulation and vibration isolation.

WIRING

1. **FUSE:** A fuse of the proper size must be installed in line with the main power in order to prevent damage to your wiring. It should be connected to the battery positive terminal or as close to the battery as possible. Use the fuse holder and fuse provided and replace only with the same size fuse. The **LINEAR POWER™ 901**© uses a **20 amp AGC** fuse.

WARNING: OVERFUSING WILL DAMAGE THE AMPLIFIER

2. **MAIN POWER**

The free end of the fuse holder wire should be connected to the large red wire from the amplifier. **IMPORTANT:** Solder or crimp all connections. Connect the other end of the fuse holder to the + terminal on the battery.

3. **MAIN GROUND**

Connect the large black wire to a solid frame member via a bolt or self-tapping screw. If in doubt about the adequacy of the ground, extend the ground wire to the negative battery terminal.

4. **+12V FOR TURN-ON**

The red and white wire is not a main power source for the amplifier, but acts as an electrical switch to turn the amplifier on and off. It should be connected to the power antenna lead from the radio. Where no power antenna lead exists, a source of 12 volts connected through a toggle switch will do. **DO NOT CONNECT DIRECTLY TO A SOURCE THAT WILL LEAVE THE AMPLIFIER PERMANENTLY ON, AS THIS WILL DRAIN THE BATTERY.**

5. **SIGNAL INPUT**

The RCA (Phono) Jack inputs will accommodate either high or low level signals, ranging from 200mv to 5 volts. For use with a high level source that is intended to drive speakers directly, attach speaker leads to male RCA Plugs and insert into the inputs. **Make sure that the positive speaker leads are attached to the striped wire of the high level adaptor.**

6. **SPEAKER OUTPUT**

Connect the gray wire to the right speaker's (+) terminal. Connect the green wire to the left speaker's (+) terminal. Connect one of the black wires to the right speaker's (-) terminal. Connect the other black wire to the left speaker's (-) terminal. **(See wiring diagram next page)**

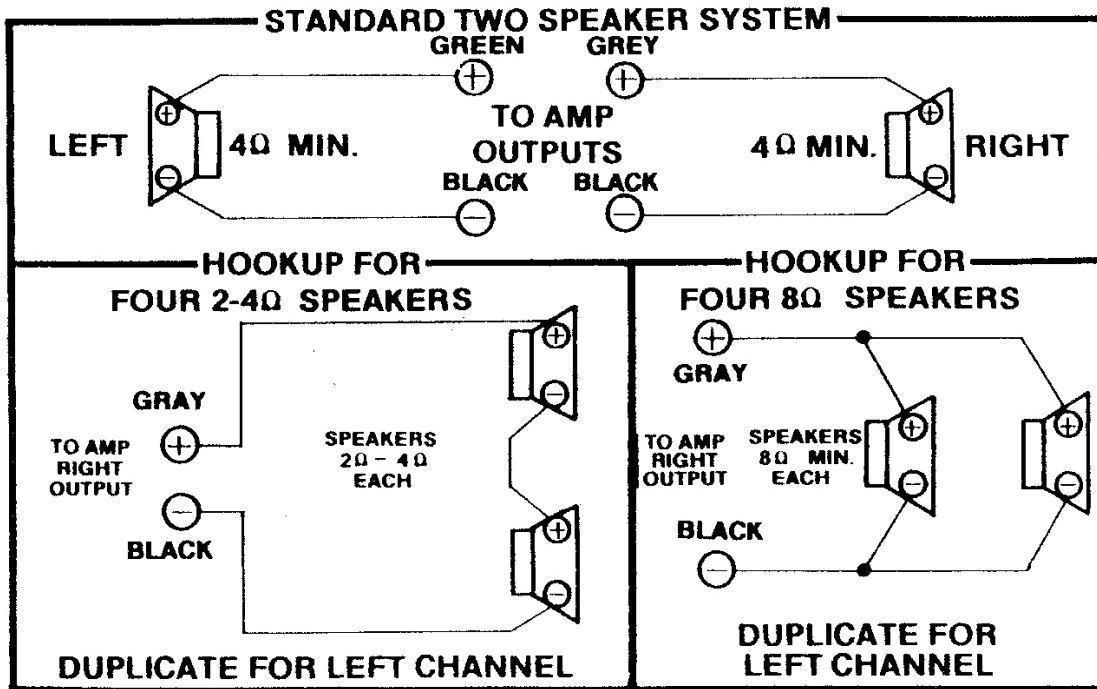

Model 901 Speaker Connector

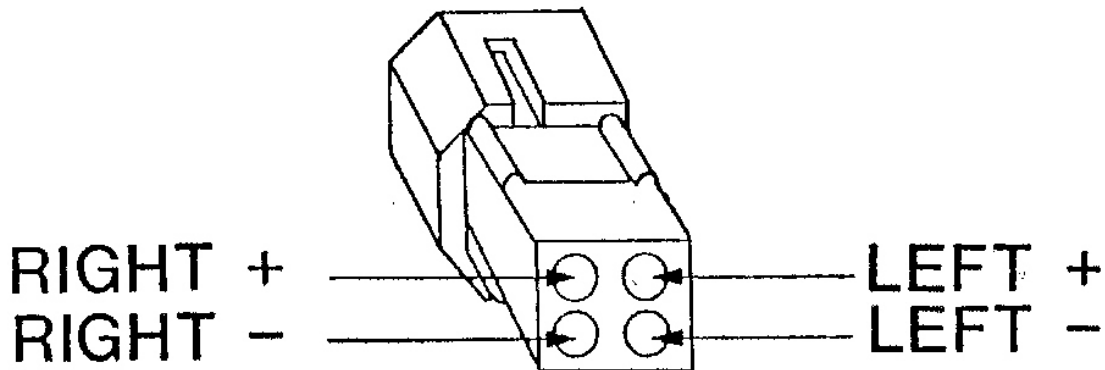

OPERATION IN BRIDGE MODE

The **Model 901**® amplifier **must** use an external pre-amp or crossover to be used as a bridgeable amplifier. They must be bridged using a **Linear Power™** crossover such as the **Linear Power™ XO-1**®, **XO-2**®, or similar brand crossover or pre-amp with inverting capabilities. One channel of the inputs of these amplifiers must receive an inverted signal in order to have the needed inverted signal on one channel at the output. Speaker connection can then be made from LEFT (+) and RIGHT (+). This amplifier is a **minimum** of 8-ohm bridgeable, for utmost reliability and sound quality. This amp is not recommended for 4-ohm bridged loads.

OPERATION/ADJUSTMENT

Apply power to the system. Amp will come on after a slight delay. Turn volume control up on tape deck or radio. If power output is adequate, leave gain control where it is. If volume is low slowly increase gain on the amplifier by turning the gain clockwise with a screwdriver. On some radios, which have very low-level outputs, a Preamp or Line Amp may be necessary.

NOTE: IT IS VERY IMPORTANT THAT THE GAIN CONTROL BE TURNED DOWN AS FAR AS POSSIBLE. IN ORDER THAT UNWANTED ENGINE NOISE BE KEPT TO A MINIMUM.

GENERAL TROUBLESHOOTING

NO SOUND: Check all connections. Check main power fuse. Check accessory fuse. With a trouble light or meter be sure +12V is present at the amplifier on (1) The large Red Wire (2) The (Red/White) wire but not at the large Black. Check by substitution or other method for proper operation of music source.

BLOWS FUSE: Check all connections to be sure all power wires and speaker wires do not touch ground or each other. Re-check polarity of main power wires.

SHUTS OFF: As this amplifier is equipped with a thermal and a short circuit shutdown system in the unlikely event of excessive temperatures due to high ambient temperature, improper speaker impedance, etc. The amp will turn itself off. If this happens, the amp will turn itself back on when cool **enough**. To avoid damage to the speakers, turn the volume to a minimum while waiting for the amp to turn itself back on.

NOISE NOTES

Unwanted noise is the worst single problem encountered in automotive amplifier installations. Most noise problems start at the music source. Your **LINEAR POWER** amplifier will accurately reproduce any sound present in the signal path. **NO** amplifier can discriminate between music and engine noise. Several basics must be kept in mind when preventing noise problems.

1. The hookup method with the least noise in one vehicle may be the noisiest in another.

2. Most noise problems start at the music source. Your **LINEAR POWER™** amplifier will accurately reproduce any sound present in the signal path. **NO** amplifier can discriminate between music and engine noise.

3. Many noise problems exist due to a lack of car maintenance. A general tune-up and periodic check of the vehicle's charging system should be made.

4. In some situations the complete elimination of engine noise may not be possible. In those cases, one can only hope for an acceptable degree of reduction. Consult your professional auto sound dealer to aid you in those "tough" cases.

INSTALLATION RULES

1. Use shielded cables whenever a preamp level music source is used.
2. All connections must be tight, free from corrosion and paint, etc. and insulated.
3. Route all signal cables away from existing wiring in the vehicle.
4. If possible, avoid mounting the amplifier in the dash or on the firewall, as noise may be induced due to the proximity of noisy wiring and switches.

NOISE TROUBLESHOOTING PROCEDURES

1. Start engine and let idle.
2. Turn system on. **ADJUST INPUT GAIN ON AMP SO THAT IT IS TURNED DOWN AS FAR AS POSSIBLE TO STILL PRODUCE ADEQUATE LISTENING LEVELS.**
3. Slowly increase and decrease engine speed.
4. Take note as to the type and amount of noise while slowly varying the volume control on the music source from minimum to average levels.
5. If noise is a popping or ticking sound, increasing in speed with engine speed, the source is probably the ignition system. If the noise is a "whistle," the source is the alternator. If the noise is present only when the volume is turned up, both types of noise require similar treatments.
6. Unplug the inputs to the amplifier at the amp. Again, listen to the amount of noise. If the noise disappears, install a noise kit (which can be purchased at any Radio Shack or other electronic outlet.) (See note A)
7. If the noise remains when the inputs are removed, re-route the power connections and check for the proper ground connections (see note B).

NOTES

- A.** Install a noise kit in the main power to the music source. If the music source has a dimmer lead, install a noise kit there also. Check all grounding points for corrosion, paint, ECT. Scrape clean, and retighten if necessary. If noise continues to persist, refer to note C.
- B.** Re-route the main power ground to a different location in the vehicle. Listen carefully to the amount of engine noise through the system each time the ground is changed. If relocation of the power ground has little or no effect, obtain a high current choke (coil) with a current rating of at least one and one half times the maximum current rating of the amplifier and splice inline with amp main power wire. **IMPORTANT: SOLDER AND INSULATE ALL CONNECTIONS.** If the noise still persists mount the amp in a different location farther away from the engine compartment. Be sure all main power wires to the amp are routed away from existing wiring in the vehicle.
- C.** Touch the center pin of the music source male plug to the center hole of the amplifier female jack so that the music is heard. Prevent the outer ground contact from touching the female jack on amp. If this procedure causes noise to disappear modify the input cables by carefully removing 1-2 of the outer insulation exposing the ground braid. Cut the braid and fold back Strip 2-3 of insulation off a scrap piece of wire and wrap around the ground braid next to the plug closest to the amp and wrap the entire connection with electrical tape. Try grounding this signal ground at several different locations in the vehicle while carefully listening to the amount of engine noise at each location. Attach this signal ground wire to the location, which causes the least amount of engine noise. Only one input plug needs the signal ground wire attached, the other input need only have its ground braid broken.

SERVICE OR REPAIR

To obtain modification, service or repair, please contact our **ONLY Authorized LINEAR POWER™ Product Service Center:**

T.I.P.S. INC.
3455 Lanell lane, Pearl, MS 39208
(601) 932-8477
E-mail: ray@tipsinc.net

LINEAR POWER™
3455 LANELL LANE, PEARL, MS 39208 (601) 932-8477

Specifications

901©

Power output @ 4 ohms RMS @ 12.5 volts	45X2
THD @ full output 20-20KHz +/- 1dB	<.15%
Signal to Noise ratio	>95 dB
Intermodulation Distortion	.3%
Damping factor @ 4 ohms	>200
Frequency Response +/- 1 dB	12Hz to 150KHz
Slew Rate in volts per microsecond	6 V/uS
Dynamic headroom	1 dB
Current Draw @ Idle/Max	.75A/7.5A
Fuse rating (12 Volt Power Feed)	20A

LINEAR POWER™
3455 LA NELL LANE, PEARL, MS 39208 (601)932-8477